

IDS25 INPLANT INK DISPENSER

COLOUR MANAGEMENT EQUIPMENT

VALE-TECH

Dispensing Solutions Worldwide

www.vale-tech.com

Suitable for
UV Screen,
UV Flexo inks
and Varnishes

Applications

Typically used in Optical Media, Roll Labels, Container printing and Industrial Graphics. The IDS25 is a high duty ink dispenser designed for 24/7 operation. Its compact design, high accuracy and ease of use make it ideal for inplant colour blending.

Benefits

Compact, high accuracy, high performance Ink Dispenser with a small footprint that requires the minimum of space. High reliability and low maintenance. Installation is virtually plug and play.

Remote access feature allows direct link with the ink supplier, colour centre and the Technical Support Team providing on-line training and software maintenance.

 The Vale-Tech Ink Manager™ software ensures complete control of the dispensing and colour blending process.

The modular design of the IDS series allows complete flexibility for any configuration of ink containers.

For example: By linking external pumps to the IDS25, high usage colours or coatings can be dispensed from BULK containers such as 180kg drums, totes and IBCs.



IDS2516

Features

- PANTONE® licensed software.
- Long life dispense valves, fitted with Teflon seals and anti-drip nozzles.
- Incorporates the Vale-Tech range of high accuracy, stainless steel enclosed balances.
- Fixed ink reservoirs of 25kg capacity
- Blending colour batches from 100g to 25kg to an accuracy of +/- 0.1g
- Up to 24 ink reservoirs
- Ink reservoir incorporates ink level sensor, real time ink levels with low ink warnings.
- Agitation option

IDS25 INPLANT INK DISPENSER

COLOUR MANAGEMENT EQUIPMENT

VALE-TECH

Dispensing Solutions Worldwide

www.vale-tech.com

TECHNICAL INFORMATION

Model IDS25: Medium Batch Dispenser
Blending colour batches from 100g to 25kg

Main module:

W=55" (1400 mm) Ship (1550 mm)

12-16 pot D=64" (1620 mm) (1700 mm)

H=63" (1595 mm) (1675 mm)

Each 4 pot extension add

D=23" (580 mm) ship (680 mm) W and H as main unit.

Unladen weight: 475Kg Crated weight: 575Kg

Extension: 100Kg Crated weight: 170Kg

No. of reservoirs: Up to 24 x 25Kg capacity
(configurable to allow colours to be doubled up as required)

Dispense Weigh range:

(option expandable to 25Kg x1g)

100g to 10Kg in increments of +/- 0.1g

Dispense valve: Air operated double actuator, fine/coarse,
incorporating PTFE (Teflon) diaphragm seals.

Flow rate: Typically, 2-3Kg per minute.

Software: The Vale-Tech Ink Manager™ software with
auto-dispense extension.

System status and interlocks

Blend container placement and size detection

Blend quantity limiter

Low ink reservoir sensing

Low pressure air supply cut-off

Services

Electrical: 110—230v 50 Hz 4A/1000W

Air supply: 6-8 Bar (85-110 psi) clean and filtered

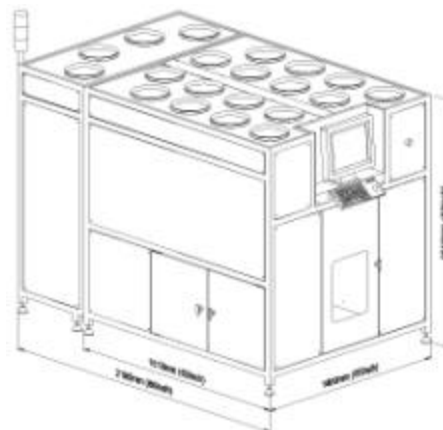

Machine options

CQ or VQ AUTO-FEED Queuing systems to be added to your dispenser, allowing up to 12 blends to be produced automatically and seamlessly.

LV205-10 Bulk material extension. 205 litre drum dispenser to deliver high usage materials from drums.

LLK Remote access pack. Either telephone or server based communications utilising Laplink PC software. Includes headset and camera.

SP-1 Scan Pack. Barcode labelling and scanning package. Includes barcode label printer, laser printer, hand-held laser scanner and software.

SP-2 As SP-1 but excludes laser printer.

SL Spectro link to Gretag, X-Rite® and Datacolor systems

IDS25-25Kg balance upgrade. High capacity balance assembly allows blends of up to 25Kg (5 gallons).

IDS25-AG Ink vessel agitator (stirrer) comprising air motor and mixing paddle.

IDS25 Series of Dispensers

IDS2512 comprises 10Kg Balance, 12 double actuator dispense valves and 12 x 25Kg reservoirs.

IDS2516 comprises 10Kg Balance, 16 double actuator dispense valves and 16 x 25Kg reservoirs.

IDS2520 comprises 10Kg Balance, 20 double actuator dispense valves and 20 x 25Kg reservoirs.

IDS2524 comprises 10Kg Balance, 24 double actuator dispense valves and 24 x 25Kg reservoirs.

PANTONE® is a registered trademark of Pantone, Inc.

Manufactured by VALE-TECH LTD

Unit 12, Depot Road, Newmarket, Suffolk, CB8 0AL, UK

e-mail : sales@vale-tech.com

TEL: +44 (0)1638 668583 FAX: +44 (0)1638 676720

www.vale-tech.com